

# **Attachment A4**

**Design Excellence Strategy**

# Design Excellence Strategy

The O'Connell Precinct, Sydney

# 1.0 Overview

## 1.1 Overview

This Design Excellence Strategy has been prepared by Ethos Urban on behalf of Lendlease (the Proponent).

In accordance with clause 1.2 of the City of Sydney Competitive Design Policy 2012 (the Policy) and clause 3.3.2 of the Sydney Development Control Plan 2012 (Sydney DCP 2012) this Design Excellence Strategy defines:

- the location and extent of the competitive design process;
- the type of competitive design process to be undertaken;
- the number of designers involved in the process;
- whether the competitive design process is seeking to enable additional height or floor space;
- options for distributing any additional floor space ratio or height which may be granted by the consent authority for demonstrating design excellence through a competitive design process; and
- target benchmarks for ecologically sustainable development.

The Proponent has elected to carry out an invited architectural design competition with a minimum of five (5) invited competitors.

To ensure that the development of the site proceeds in a timely manner, it is envisaged that the competitive process will begin as soon as practical after the post-exhibition endorsement of the planning proposal by the Central Sydney Planning Committee and the endorsement of the Design Competition Brief by the City of Sydney.<sup>1</sup>

## 1.2 Objectives of the Design Excellence Strategy

The objectives of this strategy are to:

- Establish a methodology for the Proponent to implement a competitive design process for the redevelopment of the subject site, in accordance with the Policy.
- Ensure that the competitive design process works within the framework of this approved Design Excellence Strategy.
- Confirm the number of architectural practices to participate in the competitive process and how these will be selected.
- Establish the process for the selection of a competition jury.
- Set out the approach for establishing a Competition Brief that ensures:
  - The Proponent's objectives are balanced with the Consent Authority's design excellence requirements.
  - The achievement of design and architectural diversity.
  - Procedural fairness for competitors.
- Ensure sustainability initiatives and ecologically sustainable development targets are defined and developed through the Design Competition, detailed design development and construction phases through to completion of the project.
- Ensure that design integrity is continued in the subsequent detailed development proposal through construction phase to completion of the project.

---

<sup>1</sup> **Note:** It is not expected that this Design Excellence Strategy represents an approval from the consent authority for a departure from the relevant SEPPs, Sydney Local Environmental Plan 2012 (Sydney LEP 2012) or Sydney Development Control Plan 2012 (Sydney DCP 2012) controls (as proposed to be amended by the Planning Proposal for the site). Where there is any inconsistency between this Strategy and the relevant SEPPs, LEP or DCP (as proposed to be amended by the Planning Proposal for the site), the relevant SEPPs, LEP or DCP (as amended) prevail.

## 2.0 Design Excellence Strategy

### 2.1 The location and extent of the competitive design process

The site of the proposed commercial tower is located in The O’Connell Precinct. The site is legally described in **Table 1**, and the Precinct has a total area of 6,737.4m<sup>2</sup>

**Table 1 Site description**

Address	Lot Reference
1 O’Connell Street, Sydney	Lot 1 DP814858
8 Spring Street, Sydney	Lot 2 DP172068
10 Spring Street, Sydney	Lot 1 DP74923
	Lot 1 DP176768
16 Spring Street, Sydney	Lot 1 DP724946
17 O’Connell Street, Sydney	Lot 2 DP74923
19 O’Connell Street, Sydney	Lot 1 DP131917
23 O’Connell Street, Sydney	SP63932

As illustrated in **Figure 1**, the Precinct includes a number of existing buildings, the majority of which are anticipated to be demolished to facilitate the renewal for the new commercial redevelopment. Of note, the heritage listed at 19 O’Connell Street building will be retained, as well as the existing 1 O’Connell Street commercial building, including the heritage listed facades of 1 O’Connell Street.

A single Design Competition is proposed to be undertaken and is intended to apply to the area of the site highlighted in **Figure 1**, and is to be guided by the envelope illustrated at **Figure 2**. The Design Competition will consider the context of the retained 1 O’Connell Street building, but will not apply to the tower of the 1 O’Connell Street building and portions of the existing podium.



**Figure 1 Site location**

Source: Nearmaps and Ethos Urban

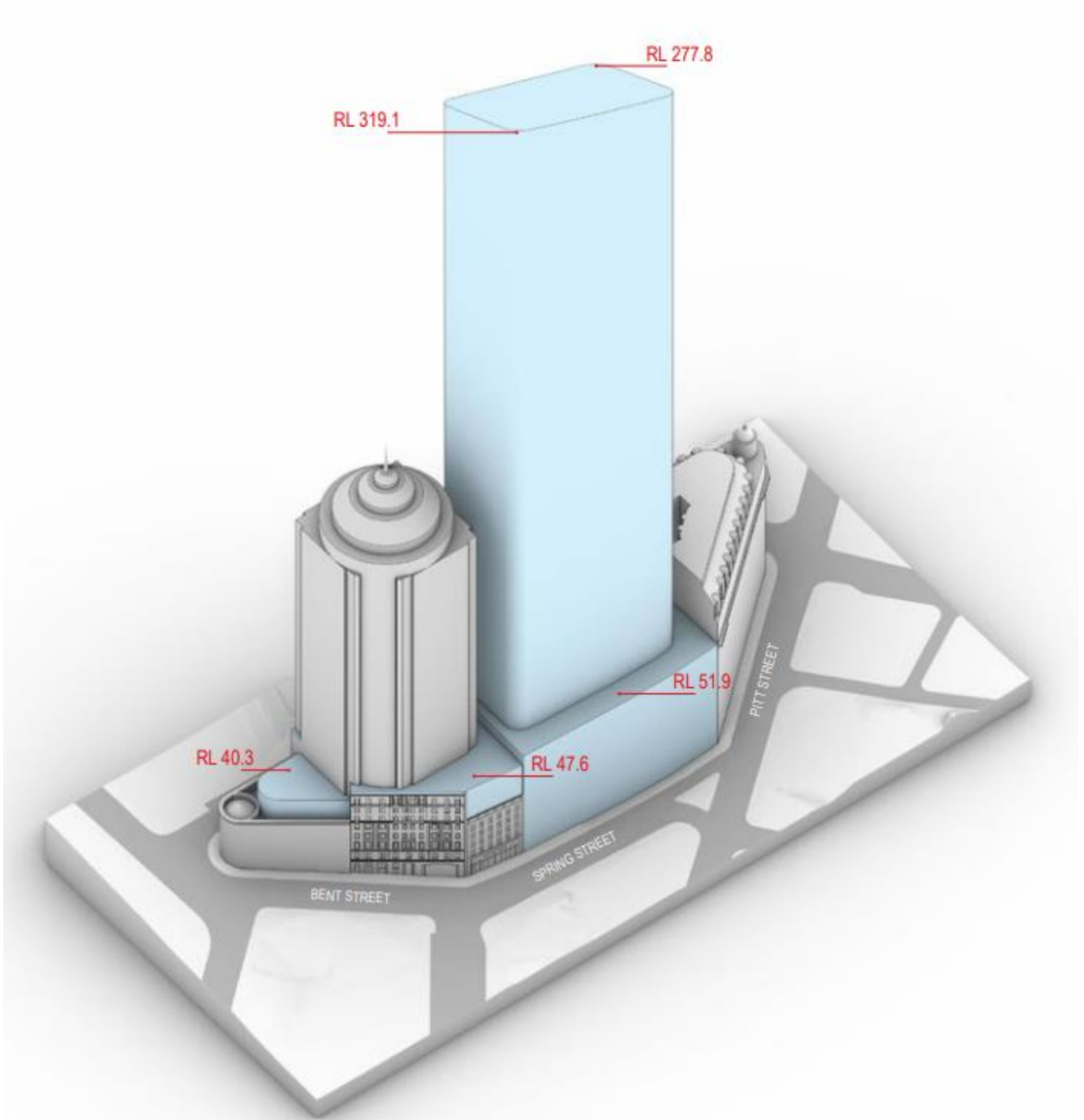

**Figure 2** Extent of competitive design process in blue (podium and western tower), axonometric view

Source: Stewart Architecture and Matthew Pullinger Architect

## 2.2 The type of competitive design process to be undertaken

The Proponent has elected to conduct a single **Invited Architectural Design Competition** for the project as defined under the Policy. The process is to be undertaken prior to the lodgement of a detailed Development Application for the redevelopment of the site as planned in the site-specific Planning Proposal.

The Invited Architectural Design Competition will be conducted primarily in accordance with the Policy and Competitive Design Model Brief, (including draft amendments) however it will also draw on efficiencies supported within the City of Sydney Competition Protocols COVID 19, dated 5 May 2020. Endorsement of the Competition Brief will be sought from City of Sydney staff prior to commencement of the Design Competition.

## 2.3 Selection of competitors

The Proponent will undertake an Invited Design Competition with a minimum of (5) invited competitors. The selection of the invited competitors will be determined by the Proponent in consultation with City of Sydney staff, as follows:

- A Competitor may be a single person or firm, or a number of firms working in partnership, constituted of a principal/lead architect supported by an executive architect(s).
- At least 50% of competitors are to include local or national Australian firms.
- A Competitor will either be a person, corporation or firm registered as an architect in accordance with the NSW Architects Act 2003, or, in the case of interstate or overseas competitors, eligible for registration with their equivalent association.
- At least one (1) competitor is an emerging architect or the majority of competitors must be in partnership with emerging architects.
- Competitors must demonstrate that they meet a gender representation ratio of at least 40% non-male members in their design team.

## 2.4 Establishment of the competition jury

The Competition Jury will comprise six (6) members in the following composition:

- Three (3) members nominated by the City of Sydney consent authority, who have no pecuniary interests in the development proposal or involvement in approval processes;
- Three (3) members nominated by the proponent including one (1) independent member (a person who has no pecuniary interest, nor is a pending or contracted employee or consultant to the proponent).

Jury members are to:

- Represent the public interest.
- Be appropriate to the type of development proposed.
- Include only persons who have expertise and experience in the design and construction professions and related industries.
- Include a majority of registered architects with urban design expertise.

## 2.5 Competition Brief

The Competition Brief will be prepared on behalf of the Proponent who will liaise with the City of Sydney for endorsement prior to commencement of the Design Competition, as per clause 2.3 of the Policy. In establishing the Competition Brief, the Proponent will ensure that:

- All details regarding the conduct of the Design Competition are contained within the Competition Brief.
- The Competition Brief and appended documents are reviewed and endorsed in writing by the City of Sydney prior to its distribution to Competitors, Competition Jury and technical advisors.
- The Competition Brief is to be generally in accordance with the Competitive Design Model Brief and the City of Sydney Competitive Design Policy and is to be approximately 30 pages in length (excluding the Competition procedures).

## 2.6 Proposed allocation of up to 10% additional floor space

The design competition will be pursuing up to 10% additional floor space under a site-specific clause resulting from the Planning Proposal.

The Planning Proposal and Draft DCP amendments support a podium and tower envelope that can accommodate the maximum site specific permissible FSR (inclusive of the 10% additional floor space available under the proposed site-specific clause), being 26:1.

## 2.7 Options for distributing floor space within the building envelope

The distribution of the additional floor space is to be considered by the Competitors in the Design Competition and must be consistent with provisions contained in the Planning Proposal (including Draft Sydney DCP 2012 amendments) for the site.

## 2.8 Ecologically sustainable development targets

The resulting commercial tower the subject of the Design Competition is to achieve the following minimum ecologically sustainable development (ESD) targets:

- 6-star Green Star Design & As Built v1.3 certified rating
- 5.5 Star NABERS Energy rating (Commitment Agreement)
- 4 Star NABERS Water rating (Target)
- 5 Star NABERS Waste rating (Target)
- WELL Platinum Shell & Core v2 certified
- Climate Active Carbon Neutral Building certification

ESD targets and sustainability initiatives will be carried through the competition phase, design development, construction, and through to completion of the project to deliver an exemplar of environmentally sustainable development.

## 3.0 Design integrity

The architectural firm of the winning scheme selected through the Invited Architectural Design Competition, is to be appointed as the Design Architect for the project and will perform this role until the completion of the project. The role of the Design Architect will include at a minimum the following:

- Prepare a Development Application;
- Prepare the design drawings for a construction certificate;
- Prepare the design drawings for the contract documentation; and
- Maintain continuity during the documentation and construction phases through to the completion of the project.

The winning architect may work in association with other architectural practices but is to retain a leadership role over design decisions.